

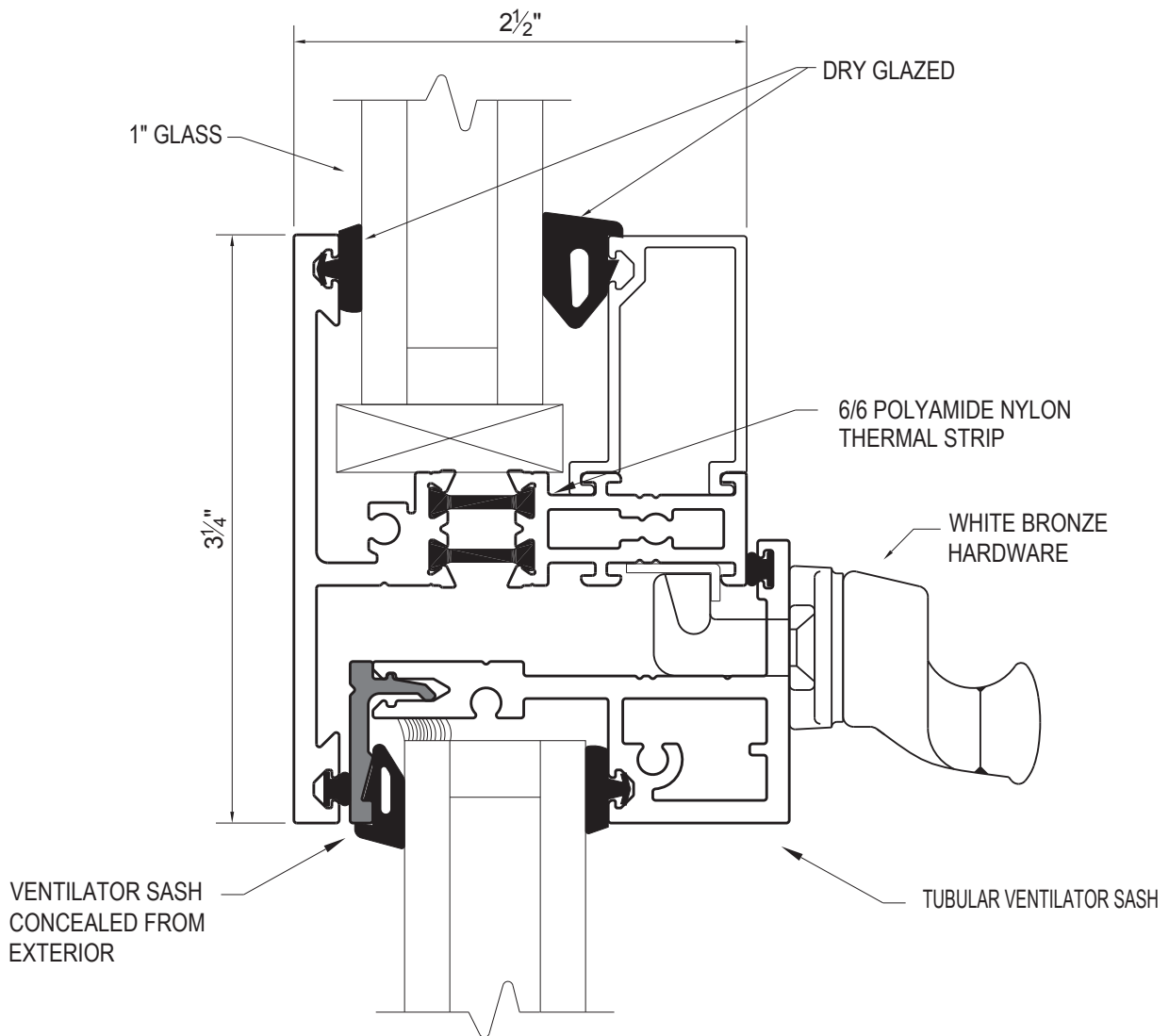

The 4800 Series has equal sitemlines for both vent and fixed lites making the ventilators concealed and indistinguishable from the fixed lites. Thermally broken using Thermal Strip technology© allows different finishes interior and exterior. Available as inswing projected ventilators and casements or fixed lites or combinations of each.



SCALE = FULL SIZE

Features:

- AAMA AP-HC65, F-AW65 Performance Class
- Full 2 1/2" deep frame with tubular muntins, meeting rails and ventilator sash. Ventilator sash is angle reinforced. *(Consult factory for full specifications)*
- Narrow and equal site lines at vents and fixed lites. Ventilators are indistinguishable from fixed lites and concealed from the exterior.
- The thermal strip is a specially formulated and constructed extrusion of glass fiber reinforced 6/6 polyamide nylon. Besides being thermally efficient, these high strength strips have the same coefficient of expansion as aluminum so that the structural integrity of the window is intact.



Since 1906

America's finest custom windows

FIXED OVER PROJECT-IN OVER FIXED

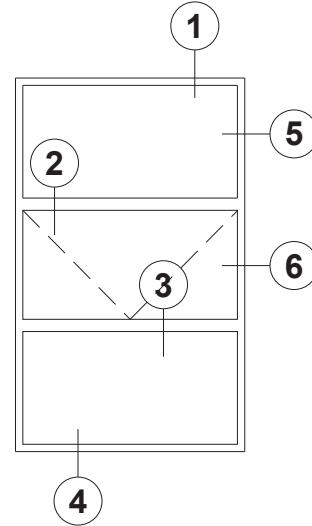
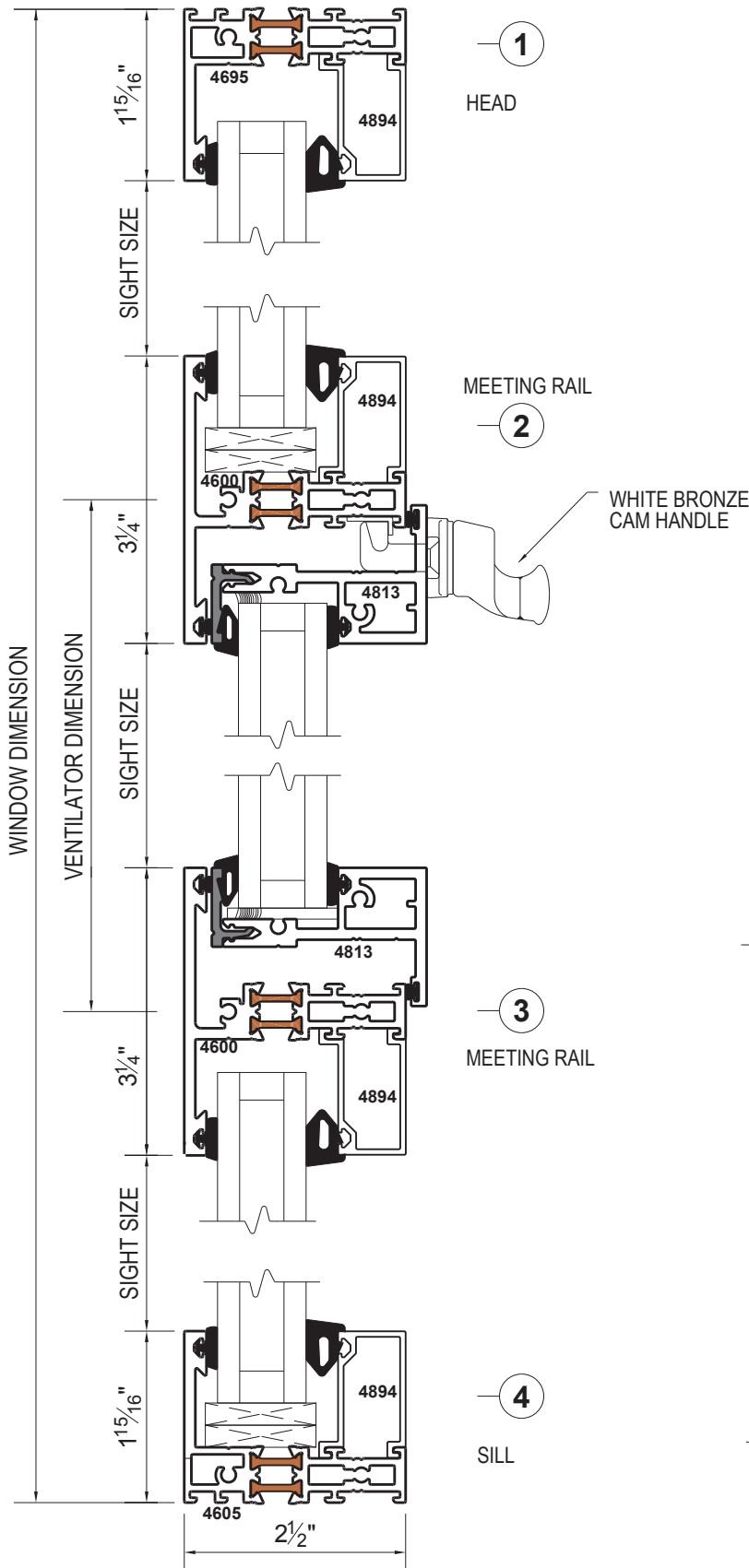

Typical Elevation

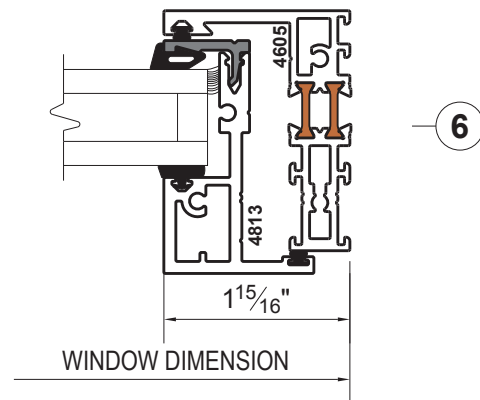
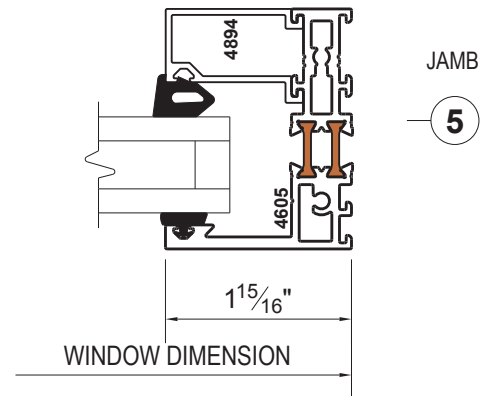

SCALE = HALF SIZE



Since 1906

America's finest custom windows

IN SWING CASEMENT

Hardware not shown. Push-pull operation with cam handles and stainless steel 4 bar hinges are standard. 5 knuckle extruded aluminum butt hinges are optional.

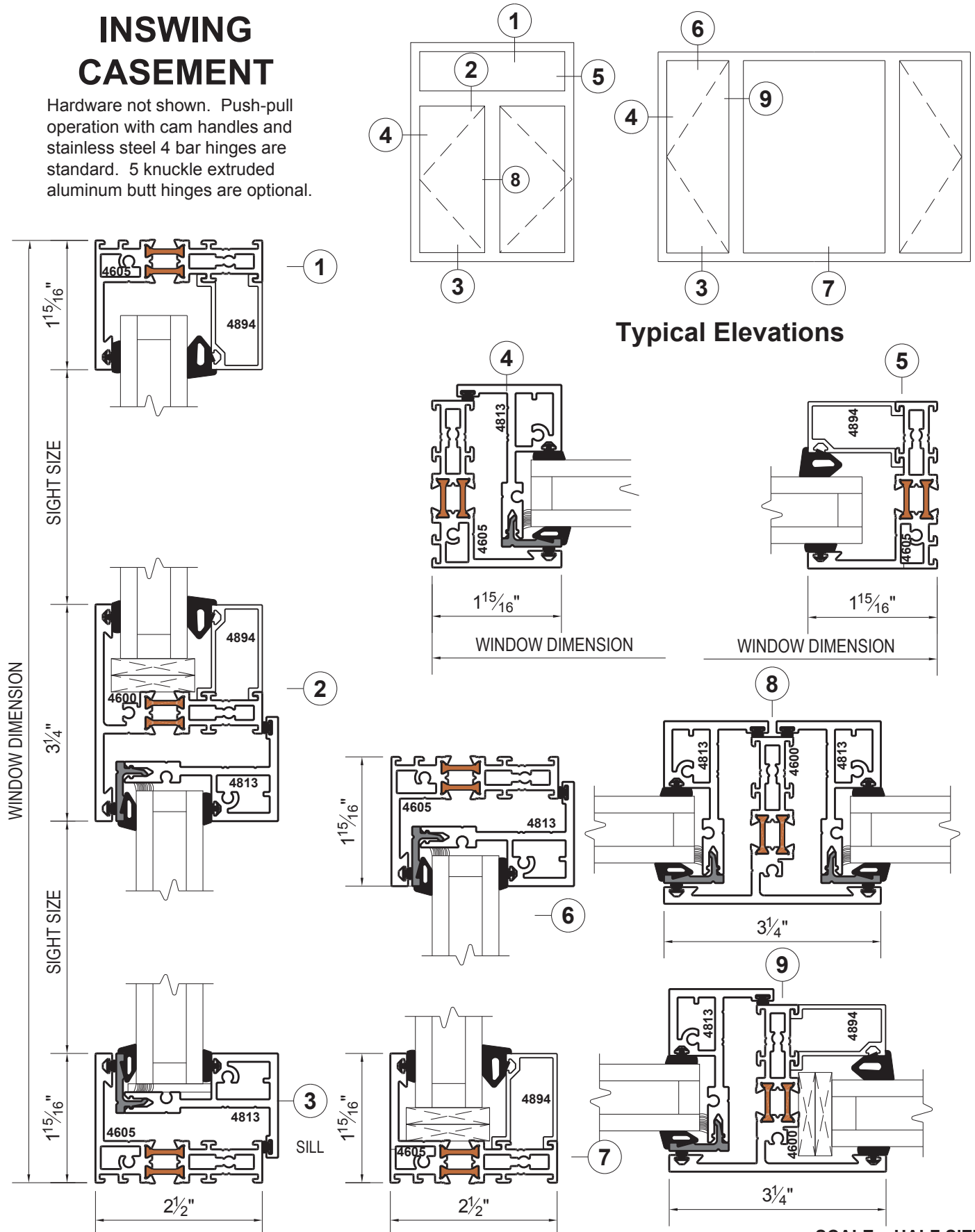

SCALE = HALF SIZE